

# AstroHalo™

High Tech Leads Industry



## 305W~315W

5BB-Monocrystalline PV Module

CHSM6610M Series (156.75)

CHSM6610M/HV Series (156.75)

CHSM6610M max system voltage 1000V standard

CHSM6610M/HV max system voltage 1500V standard

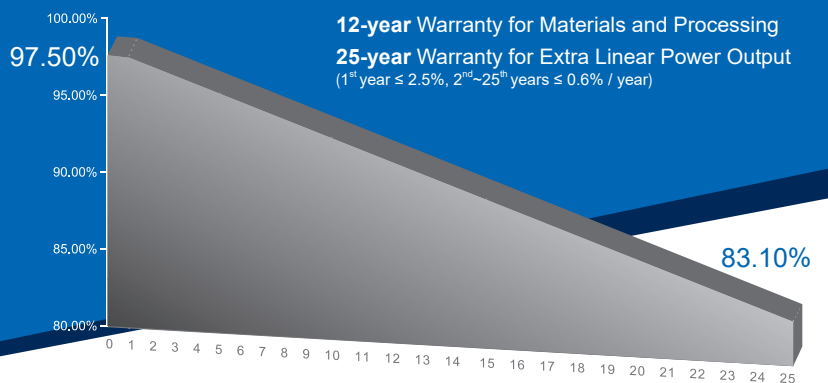

\* Optional: Black frame designed for the certain projects and applications (e.g. residential rooftop and so on)

### COMPREHENSIVE CERTIFICATES



First solar company which passed the TUV Nord IEC/TS 62941 certification audit.

### KEY FEATURES

- +5W OUTPUT POSITIVE TOLERANCE**  
Guaranteed 0~+5W positive tolerance ensures power output reliability.
- PERC INNOVATIVE PERC CELL TECHNOLOGY**  
Excellent cell efficiency and output.
- LOWER TEMPERATURE COEFFICIENT**  
Improved temperature coefficient decreases power loss in the high temperature application.
- HIGHER RELIABILITY AND DURABILITY**  
Effectively deals with harsh environments, such as sand, salt mist and ammonia resistance.
- PASSED HAIL TEST**  
Certified to hail resistance: ice ball size (d=45mm) and ice ball velocity (v=30.7m/s).
- Anti PID PID RESISTANCE**  
Excellent PID resistance at 96 hours (@85°C /85%) test, and also can be improved to meet higher standards for the particularly harsh environment.

For Global Market



**ASTRONERGY**  
A CHNT COMPANY

## ELECTRICAL SPECIFICATIONS

STC rated output ( $P_{mpp}$ )*	305 Wp	310 Wp	315 Wp
Rated voltage ( $V_{mpp}$ ) at STC	32.80 V	32.96 V	33.05 V
Rated current ( $I_{mpp}$ ) at STC	9.30 A	9.42 A	9.55 A
Open circuit voltage ( $V_{oc}$ ) at STC	40.05 V	40.18 V	40.33 V
Short circuit current ( $I_{sc}$ ) at STC	9.72 A	9.86 A	9.98 A
Module efficiency	18.6%	18.9%	19.2%
Rated output ( $P_{mpp}$ ) at NMOT	224.1 Wp	227.8 Wp	231.5 Wp
Rated voltage ( $V_{mpp}$ ) at NMOT	30.21 V	30.31 V	30.40 V
Rated current ( $I_{mpp}$ ) at NMOT	7.42 A	7.52 A	7.61 A
Open circuit voltage ( $V_{oc}$ ) at NMOT	37.15 V	37.27 V	37.41 V
Short circuit current ( $I_{sc}$ ) at NMOT	7.82 A	7.93 A	8.03 A
Temperature coefficient ( $P_{mpp}$ )	- 0.380%/°C		
Temperature coefficient ( $I_{sc}$ )	+0.042%/°C		
Temperature coefficient ( $V_{oc}$ )	- 0.284%/°C		
Nominal module operating temperature (NMOT)	46±2°C		
Maximum system voltage (IEC/UL)	1000V <sub>DC</sub> or 1500V <sub>DC</sub>		
Number of diodes	3		
Junction box IP rating	IP 67		
Maximum series fuse rating	20 A		

STC: Irradiance 1000W/m<sup>2</sup>, Cell Temperature 25°C, AM=1.5

NMOT: Irradiance 800W/m<sup>2</sup>, Ambient Temperature 20°C, AM=1.5, Wind Speed 1m/s

## CURVE

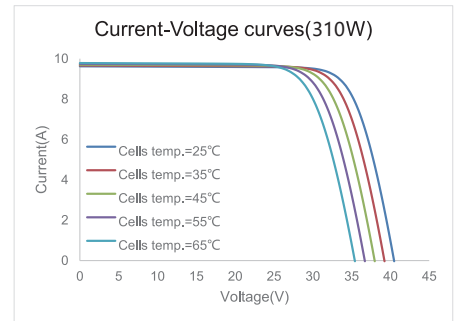
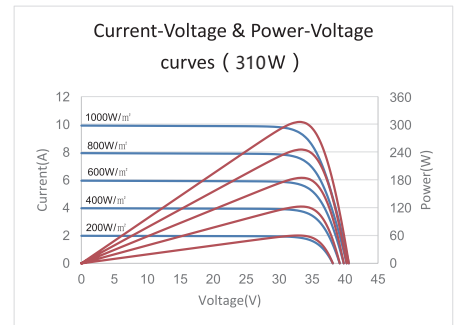

## MECHANICAL SPECIFICATIONS

Outer dimensions (L x W x H)	1650 x 992 x 35 mm 64.96 x 39.06 x 1.38 in
Frame technology	Aluminum, silver / black anodized
Module composition	Glass / EVA / Backsheet (white)
Front glass thickness	3.2 mm / 0.13 in
① Cable length (IEC/UL)	900 mm / 35.43 in
Cable diameter (IEC/UL)	4 mm <sup>2</sup> / 12 AWG
② Maximum mechanical test load	5400 Pa (front) / 2400 Pa (back)
Fire performance (IEC/UL)	Class C (IEC) or Type 1 (UL)
Connector type (IEC/UL)	MC4 compatible

① Option: 900(+)/600(-) mm or 1000 mm for defined projects in advance.

② Refer to Astronergy Crystalline Silicon PV Module Installation Manual or contact technical department.  
Maximum Mechanical Test Load=1.5×Maximum Mechanical Design Load.

## PACKING SPECIFICATIONS

① Weight (module only)	18.4 kg / 40.57 lbs
② Packing unit	31 pcs / box
Weight of packing unit (for 40'HQ container)	609 kg / 1343 lbs
Number of modules per 40'HQ container	868 pcs

① Tolerance +/- 1.0kg

② Subject to sales contract

## MODULE DIMENSION DETAILS

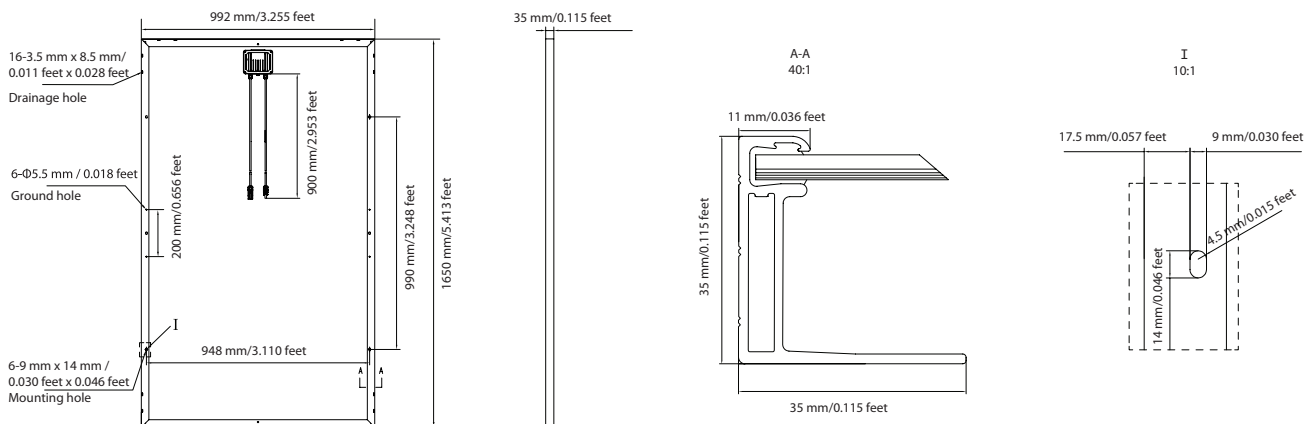

© Chint Solar (Zhejiang) Co., Ltd. Reserves the right of final interpretation. please contact our company to use the latest version for contract.